

# LUBRICATION FITTINGS

## Body Grease Fittings

Vented Cap, Positive Flow  
For Service to 10,000 PSI



### ORDERING INFO AND SPECIFICATIONS

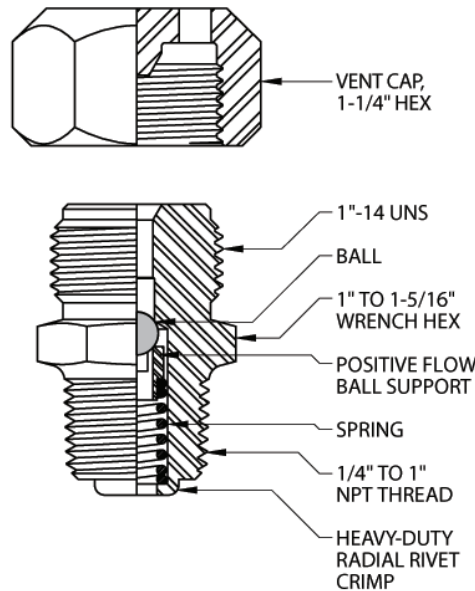

SIZE	MATERIAL	HEAT TREATMENT	PLATING	SPRING	BALL(S)	PART #
1" NPT	1215*	N/A	Zinc Cobalt	302SS	CA	FA800510
	316 SS	Annealed (NACE)	N/A	Inconel X750	K-Monel	FA800520
	4140	Rc 22 MAX. (NACE)	Zinc Cobalt			FA800530
3/4" NPT	1215*	N/A	Zinc Cobalt	302SS	CA	FA600510
	316 SS	Annealed (NACE)	N/A	Inconel X750	K-Monel	FA600520
	4140	Rc 22 MAX. (NACE)	Zinc Cobalt			FA600530
1/2" NPT	1215*	N/A	Zinc Cobalt	302SS	CA	FA400510
	316 SS	Annealed (NACE)	N/A	Inconel X750	K-Monel	FA400520
	4140	Rc 22 MAX. (NACE)	Zinc Cobalt			FA400530
3/8" NPT	1215*	N/A	Zinc Cobalt	302SS	CA	FA300510
	316 SS	Annealed (NACE)	N/A	Inconel X750	K-Monel	FA300520
	4140	Rc 22 MAX. (NACE)	Zinc Cobalt			FA300530
1/4" NPT	1215*	N/A	Zinc Cobalt	302SS	CA	FA200510
	316 SS	Annealed (NACE)	N/A	Inconel X750	K-Monel	FA200520
	4140	Rc 22 MAX. (NACE)	Zinc Cobalt			FA200530

\*or substitute material which meets or exceeds 1215