

# HIGH PRESSURE HYDRAULIC HAND GREASE GUN

- The GRM high pressure hydraulic hand gun has earned a world wide reputation in pipeline, refinery and chemical plant service. Its dependability, ease of operation and rugged construction have made it the standard for over half-a-century. Then gun's light weight (15 pounds) and ability to stand the rigors of field operation are appreciated by maintenance people from the desert to the arctic.
- The hydraulic gun uses "J" stick of valve lubricant and injectable packings.
- In operation, the hydraulic fluid is pumped into the space behind the piston, which in turn drives the free- moving, polished, hard metal alloy piston forward through the strong, precisely machined barrel. The lubricant is then forced through the high pressure hose into the giant buttonhead lubrication fitting.
- An important feature is a built-in relief valve that protects the hydraulic hand gun from damage when the supply of lubricant/ sealant is unknowingly depleted if the maintenance person continues pumping.

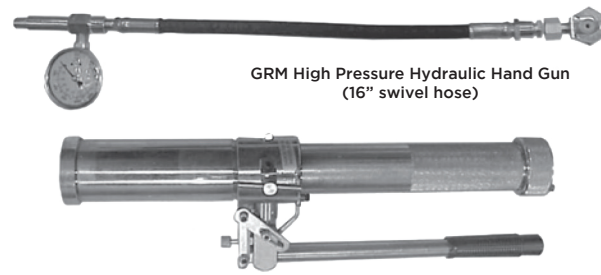

- Each GRM Hydraulic Hand Gun is equipped with a 15,000 p.s.i. gauge, which helps to determine the point where sufficient lubrication has been developed in the valve.
- This one feature gives the maintenance person precise control of lubrication for each valve plus economical lubricant use. Also furnished with each gun is a giant buttonhead coupler with adapter. It fits onto standard lubricant fittings and a 16" (20,000 p.s.i. burst) flexible swivel hose that allows lubrication in the tightest of valve manifold systems.
- Other available accessories include a vent lubrication adapter with buttonhead fitting and an adapter with hose.

## FOUR EASY STEPS TO LOADING THE GRM HYDRAULIC HAND GUN

**1.**

- Relief pressure by opening by-pass valve one full turn.

**3.**

- Using the handle, return piston to bottom of sealant barrel and close by-pass valve firmly.

**2.**

- Unscrew handle from fulcrum of lubricator, placing the hole drilled in handle over the protruding button on the sealant barrel cap.
- Rotate counter clockwise.

**4.**

- Insert "J" size stick of Desco lubricant/sealant for recommended service conditions.
- Replace cap and hose assembly. Tighten with handle as in step 2.

**NOTE: Use only hydraulic fluid specially compounded for this lubricator. Do not carry by handle.**

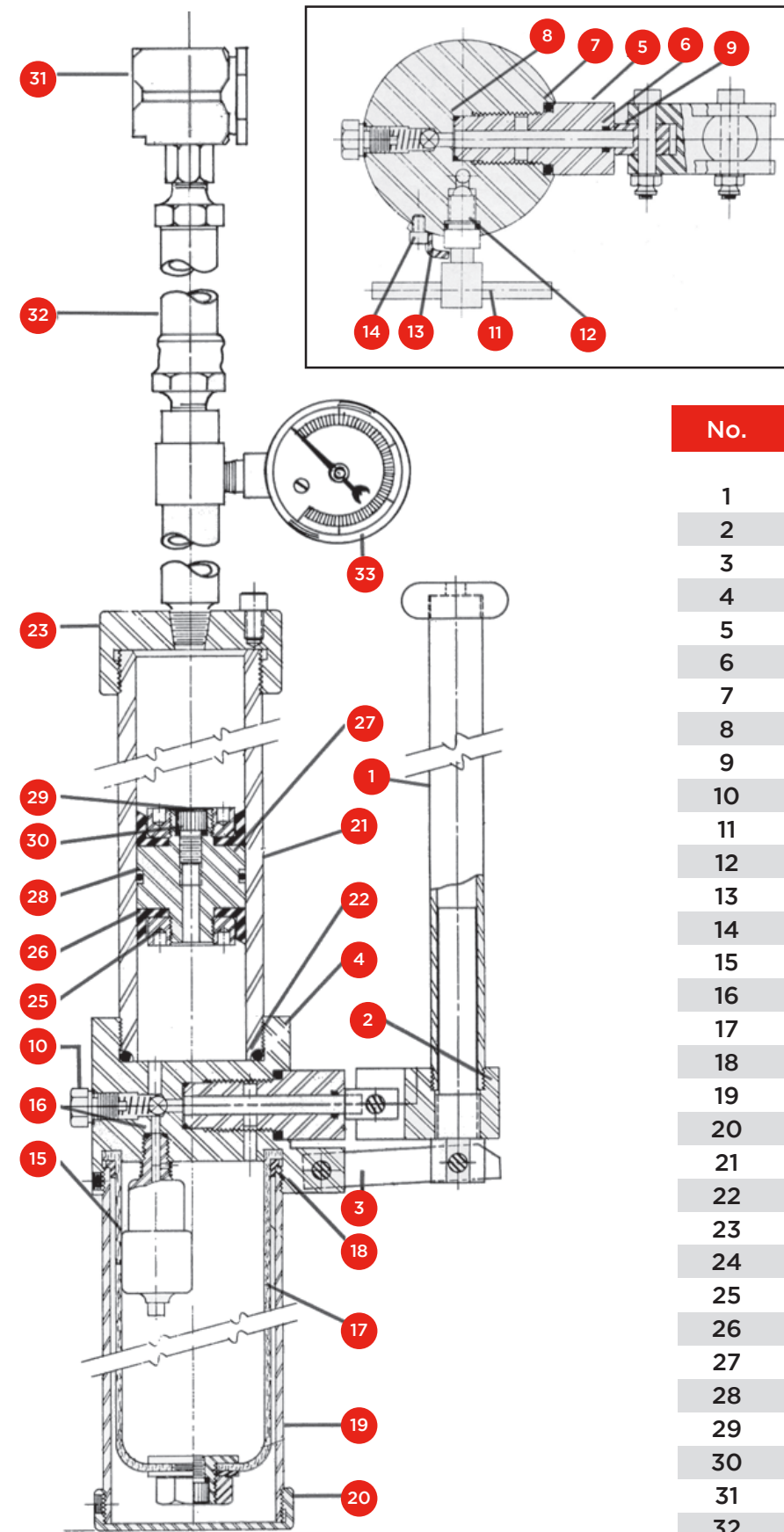

<b>Pump Piston</b>	<b>Piston Assembly</b>
<b>Part No: L-HGG-1010</b>	<b>Part No: L-HGG-1045</b>
<b>Liquid Filled Pressure Gauges</b>	<b>Hydraulic Grease Gun Repair Kit</b>
<b>Part No: L-LFG-3100</b>	<b>Part No: L-HGG-1030</b>

No.	Description
1	Handle with Knob
2	Fulcrum Assembly
3	Linkage Assembly
4	Body
5	Hydraulic Pump Cylinder w/Piston "O" Ring
6	"O" Ring (Piston Seal)
7	"O" Ring (Top of Pump Cylinder)
8	"O" Ring (Bottom of Pump Cylinder)
9	Pump Piston
10	Check Valve Assembly
11	By-Pass Valve w/"O" Ring
12	"O" Ring (By-Pass Valve)
13	By-Pass Valve Stop
14	By-Pass Valve Stop Screw
15	Internal Relief Valve
16	"O" Ring (By-Pass Valve)
17	Hydraulic Fluid Bag w/Bleeder
18	Hydraulic Fluid Bag Seal Ring
19	Hydraulic Fluid Bag Barrel
20	Hydraulic Fluid Bag Barrel Cap
21	High Pressure Grease Barrel
22	"O" Ring Grease Barrel
23	Grease Barrel Cap
24	Piston Assembly
25	Washer Nut (2)
26	Cut Leathers (2)
27	Piston
28	"O" Ring (Piston Body)
29	Piston Cap Screw (2)
30	"O" Ring (Piston Cap Screw)
31	Giant Buttonhead Coupler with Adapter
32	High Pressure Hose with Swivel
33	15,000 lb. Gauge with Adapter

## GRM GG255000 HYDRAULIC GREASE GUN INSTRUCTION

(Be sure to read complete instructions before using these Guns)

### I. OPERATION & DESCRIPTION

Hydraulic Grease Gun is a high pressure tool that should be used with caution and according to these instructions.

**IMPORTANT - This Gun is 10,000 psi rated. Do not exceed 10,000 psi.**

One end of the Gun is the Fluid Bag Barrel (19) housing the Fluid Bag. Herein, the hydraulic fluid is contained. The other end of the gun is the Grease Barrel (21). The Barrels are separated by the gun body (4) which is equipped with a Check Valve (10), Pump Piston (9) and other components. During operation, action of the Handle (1) causes the Pump Piston (9) to move out of the Cylinder (5) with the hydraulic fluid following. As the Pump Piston (9) goes into the Cylinder (5) it forces the hydraulic fluid into the space behind the Piston (27) located in the Grease Barrel (21). This Piston (27) pushes the material out through the Grease Barrel Cap (23). Numerous options are available for Grease Barrel Cap (23) attachments to transmit material to the desired pump, valve, or other equipment. The Handle (1) has a side hole near the threaded end, which will fit over the pin in the Grease Barrel Cap (23). Using the handle in this manner makes it a convenient tool to loosen and tighten the Grease Barrel Cap (27). The Handle (1) is marked with approximate 1-ounce graduations for measuring material. The Handle (1) can be used for pushing the Piston (27) to the bottom of the Grease Barrel (21).

**To ensure the Hydraulic Grease Gun will perform and operate properly use after use, keep the gun out of the weather, clean and maintained.**

### II. LOADING

Each new Hydraulic Grease Gun is ready to use, following this procedure:

- A. Unscrew Grease Barrel Cap (23).
- B. Make sure Piston Assembly (24) is all the way at the bottom of Grease Barrel (21) against Body (4).
- C. Load the Barrel (21) with material (Lubricant, Packing, Sealant, or Cleaner).
- D. Close By-Pass Valve (11). Hand tight is sufficient.
- E. Using either bulk, prepackaged, or "J" size stick material, reload Grease Barrel (21).
- F. Replace Grease Barrel Cap (23) and tighten with Handle (1).
- G. Replace Handle (1) into Fulcrum Assembly (2) and the gun is ready to operate.

Be sure to have the appropriate material transmission apparatus or hose assembly firmly attached to the Grease Barrel Cap (23) before gun operation. The Gun will need reloading if there is a sudden increase in resistance while operating the Handle (1). This is an indication that the Piston (27) has reached the Barrel Cap (23). **Use the following reloading procedure:**

- A. Open By-Pass Valve (11) to relieve pressure. One turn of the valve is sufficient.
- B. Remove Grease Barrel Cap (23) with Handle (1) as previously described.
- C. Using Handle (1), push Piston to bottom of Grease Barrel (21) so it will be flush against Body (4).
- D. Close By-Pass Valve (11). Hand tight is sufficient.
- E. Using either bulk, prepackaged, or "J" size stick material, reload Grease Barrel (21).
- F. Replace Grease Barrel Cap (23) and tighten with Handle (1).
- G. Replace Handle (1) into Fulcrum Assembly (2) and the gun is ready to operate.

**IMPORTANT** - Always make sure the Grease Barrel Cap (23) is firmly attached to the Grease Barrel (21) and be sure there is full thread engagement between these two parts before Gun operation.

Some variations of the Gun are equipped with a Latch Assembly which is to keep the Handle (1) in place when the Gun is not in use. The Gun must not be carried by the Handle (1), as this might cause the Pump Piston (9) to break. An optional Handle Assembly is available as is an optional Carrying Strap.

**NOTE** - Contact us for other operation, repair or rebuilding procedures.

### III. MAINTENANCE

Any repair or servicing that requires disassembly of the Hydraulic Grease Gun must be performed in a dirt-free environment by a qualified technician. Dispose of used parts and fluids properly.

#### Item 1. Hydraulic Fluid

The Gun comes filled with special Hydraulic Fluid. Fluid should be added or replaced as necessary using only special Hydraulic Fluid. Do not contaminated or use any other fluid. Included as a standard accessory with each new Hydraulic Grease Gun is a 4-ounce container of hydraulic fluid, which may be used for "topping" when necessary (See III, Item 2, 2C). The fluid is also available in other size containers up to 55-gallon drums Fluid bag capacity, excluding internal relief valve, is 12 ounces.

**WARNING:** Read Material Safety Data Sheet and Hydraulic Fluid label before use.

#### Item 2. Refilling the Gun with Hydraulic Fluid and purging the system of air.

2A. The Gun should be refilled with special Hydraulic fluid and purged of air only when the Piston (27) is at the bottom of the Grease Barrel (21), and flush against the Body (4).

2B. The procedure to move the Piston (27) to the bottom of the Grease Barrel (21) is as follows:

Unscrew Handle (1) from Fulcrum Assembly (2). With 1/4" pipe nipple or other fitting screwed into the Grease Barrel Cap (23), remove the Cap with Handle (1) by placing the side hole of the Handle over the pin in Cap (23) and unscrew the Cap by applying leverage against the Grease Barrel fitting. Open By-Pass Valve (11) one turn. Use Handle (1) to push Piston (27) to bottom of Grease Barrel (21) so it will be flush against Body (4). Screw Handle (1) into Fulcrum Assembly (2).

2C. Hold the Gun vertically, in a vise if available with Fluid Bag end up. Remove Fluid Bag Barrel Cap (20). Use Allen Key Wrench to remove hex socket head cap screw on the end of Fluid Bag/Bleeder Assembly. Using a spouted can, slowly fill Bag with a special Hydraulic Fluid. Do not contaminate or use any other fluid. Allow 30 minutes or the appropriate time for Gun to purge itself or air. Add fluid if necessary and replace cap screw, wrench tight. Replace Barrel Cap (20).

**IMPORTANT:** Warranty will be voided if the By-Pass Valve (10), Cylinder (5), Pump Piston (9), Piston (27) is removed from the Gun or if the Gun is disassembled or altered.



# HIGH PRESSURE HYDRAULIC HAND GREASE GUN

Part # GG255000  
Operation Instructions Manual

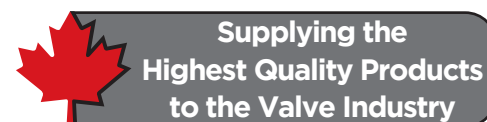

#310, 8810 - 15 St  
Edmonton, AB | T6P 0B9 | 780.416.4823  
GRMFLOW.COM SALES@GRMFLOW.COM